Short-Term Solutions

Henry J. Steadman, Ph.D.
National Dialogues on Behavioral Health
New Orleans, LA
November 10, 2015

“Mentally ill people often end up in jail because there is no other place for them in our communities”

National Coalition for Jail Reform

“Mentally ill people often end up in jail because there is no other place for them in our communities”

National Coalition for Jail Reform

1985

“Treatment-Resistant”
Clients

OR

“Client-Resistant”
Services

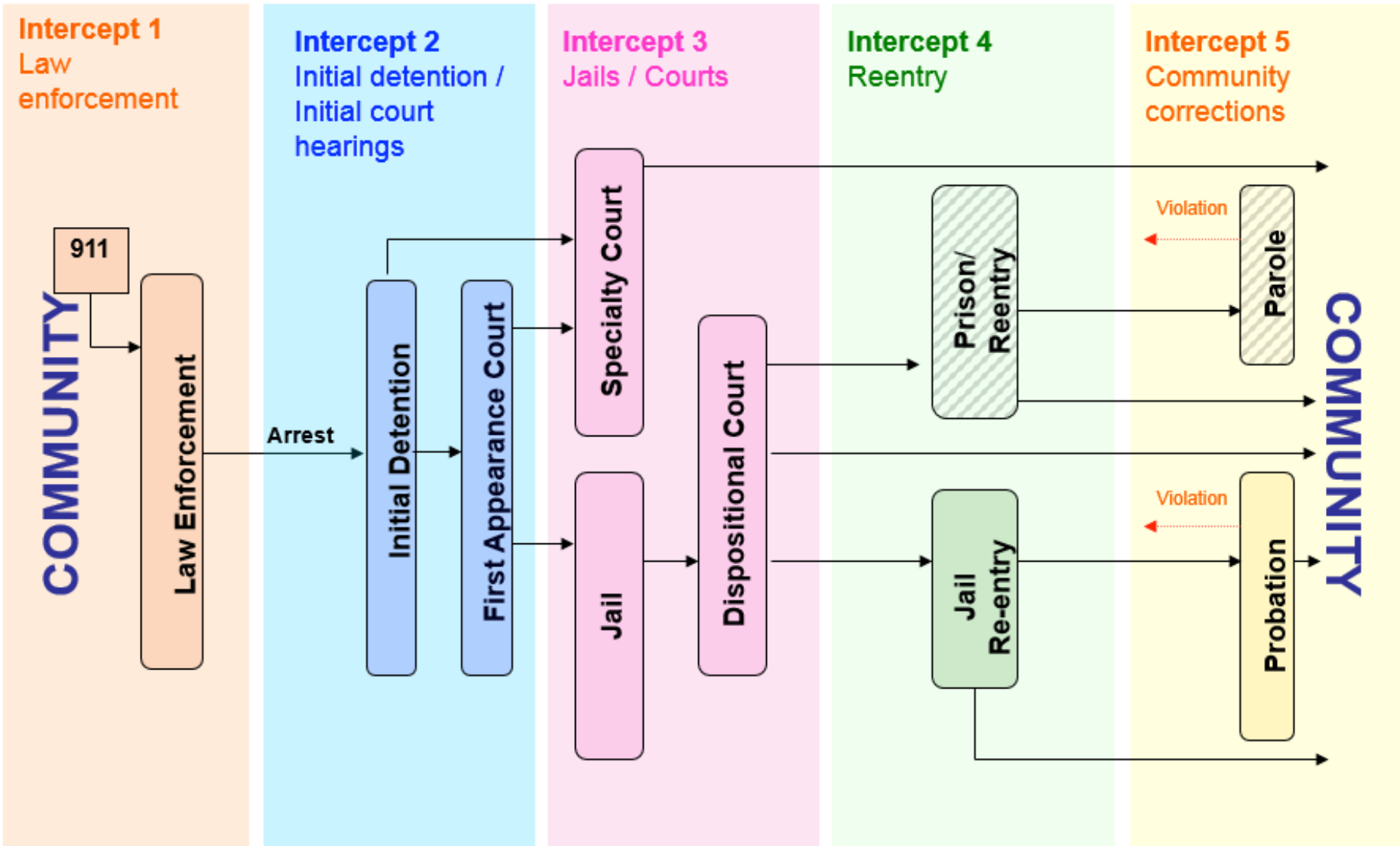

Core Principle I

Minimize inappropriate penetration into the criminal justice system.

Core Principle II

The basic unit of analysis is the community.

Core Principle III

Bringing any one program to scale will not get you where you need to be.

Goals

- Keep people out of jail who don't need to be there and get them into treatment
- Provide constitutionally adequate treatment in jail
- Link to comprehensive and appropriate integrated community-based services

Meeting Participants

Miami October, 2014

Bexar County (San Antonio) TX

King County (Seattle) WA

Johnson County (Iowa City) IA

Miami-Dade County FL

Monroe County (Rochester) NY

Montgomery County, MD

Multnomah County (Portland) OR

Pima County (Tucson) AZ

Pivotal Factor I

Centralized Point of Coordination
for Planning & Operations

Pivotal Factor 2

A Champion/Leader

Pivotal Factor 3

Information Sharing

Pivotal Factor 4

Cross-System Training

Pivotal Factor 5

Defining the Target Group

Pivotal Factor 6

Jail In-Reach